

Interpretation of MIL-STD-331 D (31. May 2017)

Fuzes Ignition Safety Devices and other Related Components

Interpretation of MIL-STD-331 D (31. May 2017) Fuzes Ignition Safety Devices and other Related Components

1	INTRODUCTION	3
2	MEASURING THE ESD EVENT	3
3	TEST EQUIPMENT REQUIREMENTS	4
4	CALIBRATION EQUIPMENT	5
5	WAVESHAPe DEFINITION.....	6
5.1	RISETIME.....	6
5.2	PULSE DURATION AND IMPULSE ENERGY	7
6	REFERENCES	8

1 Introduction

MIL-STD-331D is based on an earlier version of the same standard from 1976.

Between the versions, there has been no change to the test equipment or calibration procedure from 1976 until the latest “D” edition 2017.

There are discrepancies between the definitions and calibration procedure in MIL-STD-331D document and techniques employed by more modern standards.

MIL-STD-331 refers to many additional documents (MIL-STDs and NATO) for specific guidance on how to perform this test. These include much newer documents employing more up-to-date techniques.

The commercial standard IEC 61000-4-2 is the most up-to-date standard for ESD testing and calibration. This is recognized by many other standard authorities including the Department of Defence. MIL-STD-461G CS118 procedure adopts techniques from the IEC standard.

This document seeks to clarify the discrepancies between the requirements from MIL-STD-331D and MIL-STD-461G CS118 relating to personnel borne ESD events only.

2 Measuring the ESD Event

The original MIL-STD-331 document was written at a time when measurement of the ESD event was in its infancy. Typical oscilloscope bandwidths were in the MHz range. Evaluation of the ESD event was by eye only. A typical oscilloscope plot from those times illustrates the difficulty of evaluating the very fast ESD impulse.

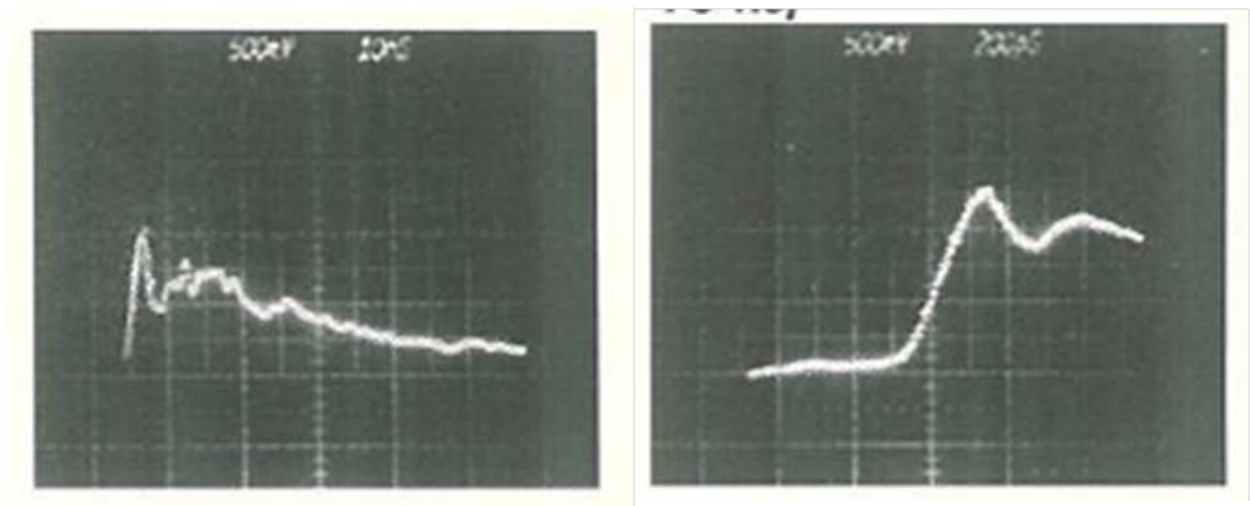

Fig. 1 ESD event measured with analogue oscilloscope

Modern test equipment and techniques have evolved to an extent that it is now possible to capture the ESD impulse and evaluate parameters automatically. A test system with 4GHz bandwidth enables fast and accurate impulse evaluation.

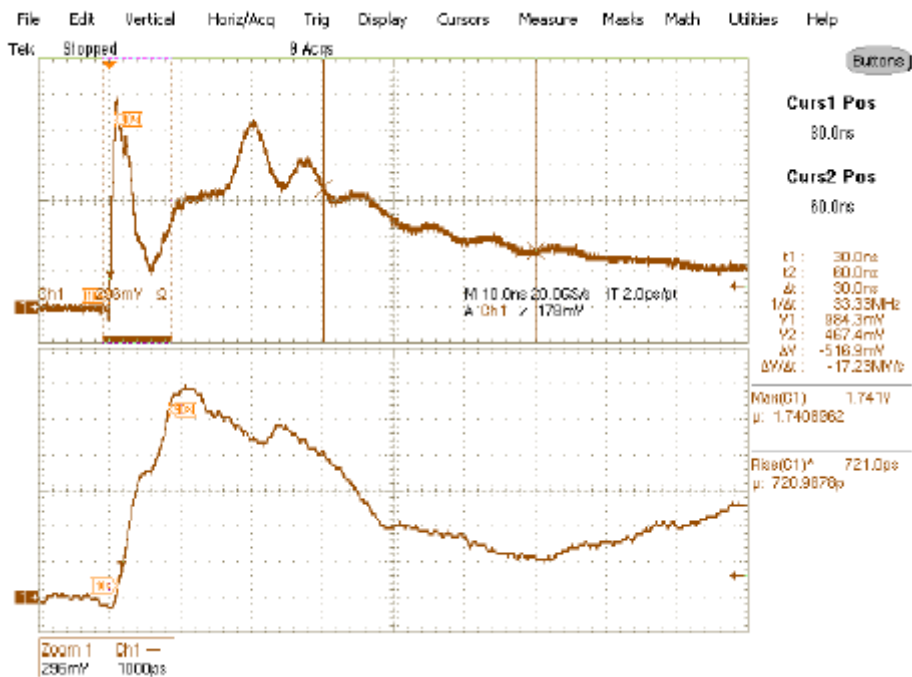

Fig. 2 ESD event measured with 4GHz DSO

3 Test Equipment Requirements

The test equipment and calibration method are described in section F1.4.2.1. EMC PARTNER AG supply the ESD3000 together with ESD3000DN4 (5000Ω) and ESD3000DN5 (500Ω) to meet the MIL-STD-331D requirements for personnel borne ESD. The test equipment is described in Figure F1-1 from MIL-STD-331D and Table F 1-I and F 1-II.

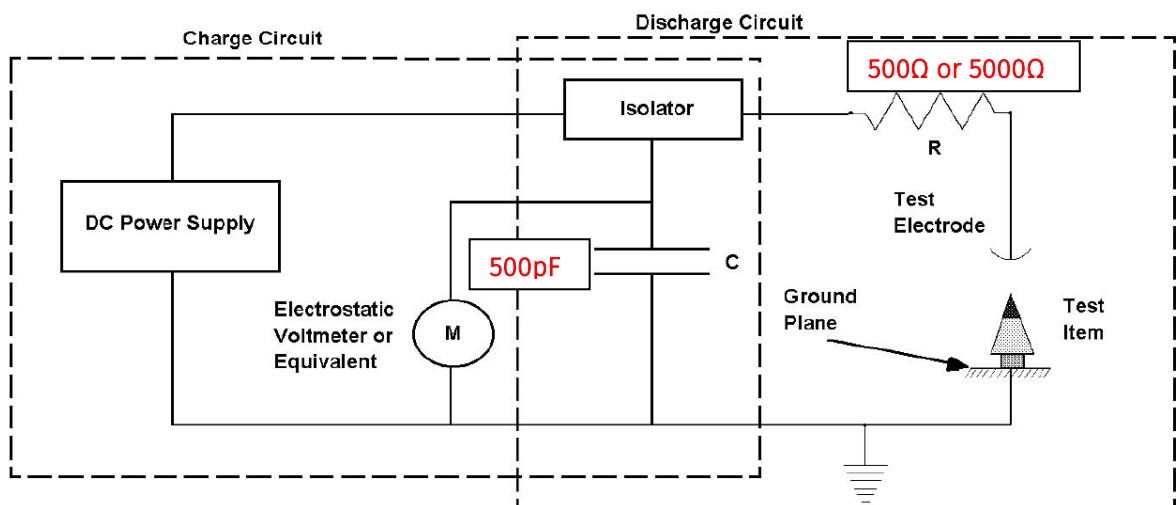

FIGURE F1-1. Functional Electrical Schematic for Electrostatic Discharge Apparatus

Fig. 3 Basic system diagram from MIL-STD-331D

4 Calibration Equipment

MIL-STD-331D indicates a calibration setup consisting of the ESD generator discharged into a 1Ω shunt displaying a voltage impulse on an oscilloscope. The standard declares that “The 1-ohm resistor should be coaxial in order to ensure the proper frequency response”.

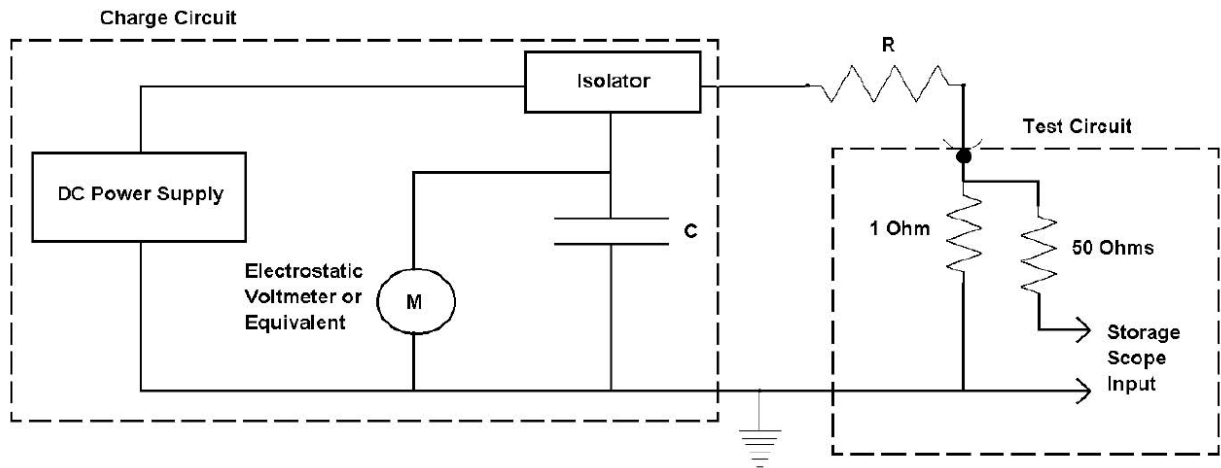

FIGURE F1-6. Personnel-borne ESD Waveform Calibration Circuit

Fig. 4 ESD system calibration setup

MIL-STD-461G CS118 and NATO AECTP-500 refer to IEC 61000-4-2 and the use of a 2Ω shunt for ESD calibration.

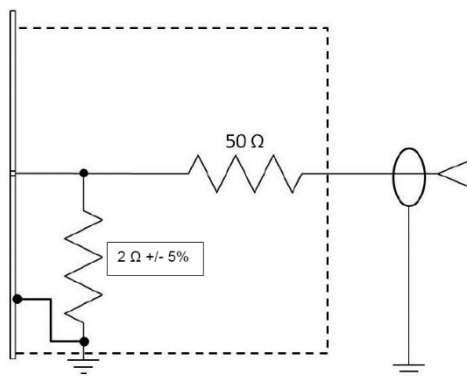

FIGURE CS118-3. Sample ESD current target schematic representation.

Fig. 5 MIL-STD-461G CS118 calibration

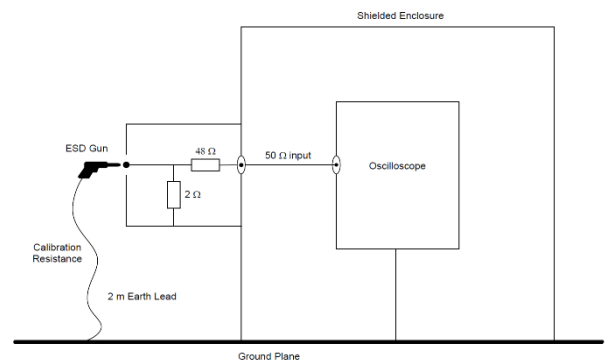

Fig. 6 NATO AECTP-500 NC12 calibration

EMC PARTNER uses the 2Ω coaxial shunt design as defined in IEC 61000-4-2 and referred to by the above standards. The frequency bandwidth is over 4GHz. All results obtained in our test reports use this calibration target type.

Using a 1Ω shunt will increase the current only, but otherwise does not have any influence on the waveform.

5 Waveshape definition

F1.7.4 Waveform characterization of the personnel-borne ESD threat. Provides only basic information about the impulse shape. Further definitions are given in

5.1 Risetime

MIL-STD-331D states simply that “Rise times are approximately 15 nanoseconds (10% to 90% of peak value)”.

Before we come to the actual rise-time measurement, we need also to consider the calibration setup whereby the ESD discharge tip is placed in contact with the coaxial resistor. This is an advice from section F1.7.4 of MIL-STD-331D.

MIL-DTL-23659 notes that “Simple calculation shows that the maximum current into a detonator from a capacitor charged to 25,000 volts through a 500 ohm resistor is 50 amps...”

While this statement is true, it does not take into account parasitic capacitances between the ESD generator and measurement shunt. These cause the initial discharge to reach higher levels than the 50A obtained by a simple ohms law calculation.

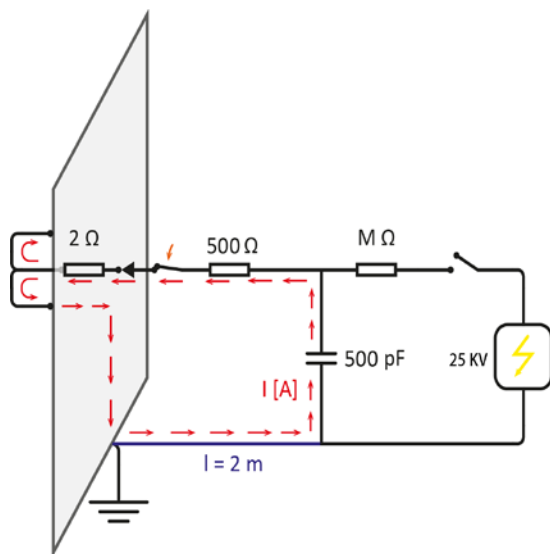

Fig. 7 ideal discharge

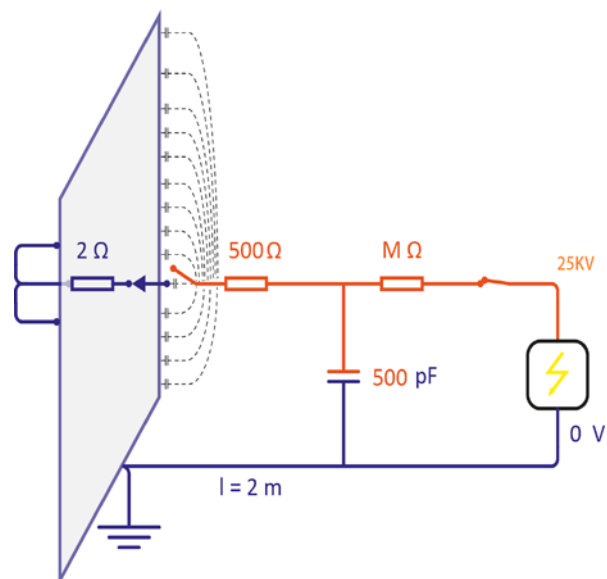

Fig. 8 Discharge with parasitic capacitance

For example, the EMC PARTNER ESD3000DN5 test report indicates a peak current of 95.5A, but this is a parasitic peak caused by the capacitance in the test setup. This peak is extremely short duration, typically < 3ns. The actual discharge event of the RC network is close to the 50A. This is confirmed by the RC time constant measurement (Tau).

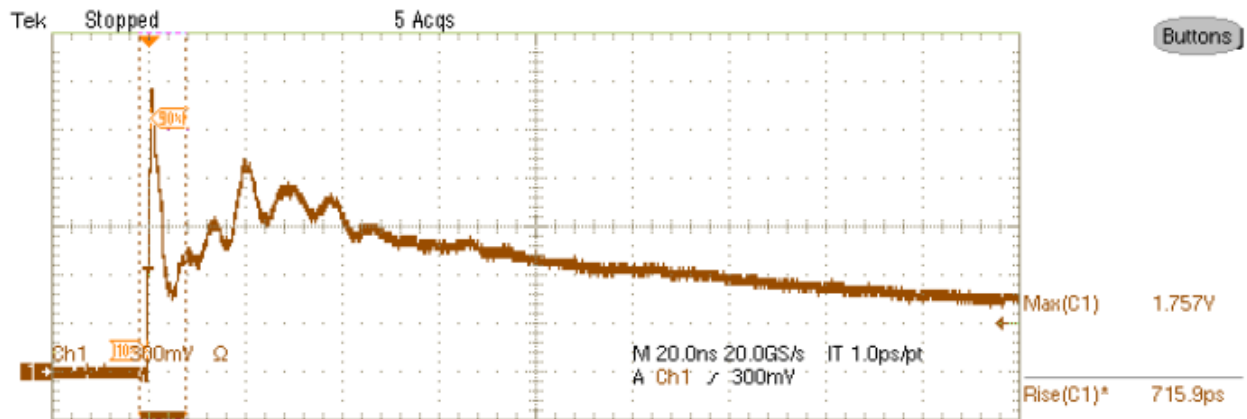

Fig. 9 ESD3000 DN5 measurement using contact mode and 2Ω shunt. DSO 4GHz bandwidth

5.2 Pulse Duration and Impulse Energy

In MIL-STD-331D the pulse duration is shown graphically in Figures F1-2 to F1-5 by a series of curves. The energy delivery capability is specified for the discharge resistors 500Ω and 5000Ω. There is no mathematical formula describing the event as in other standards

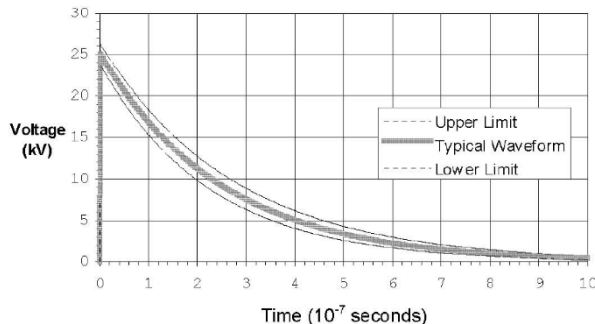

FIGURE F1-2. ESD Waveform (500 ohm series resistance)

Fig. 10 500Ω curve

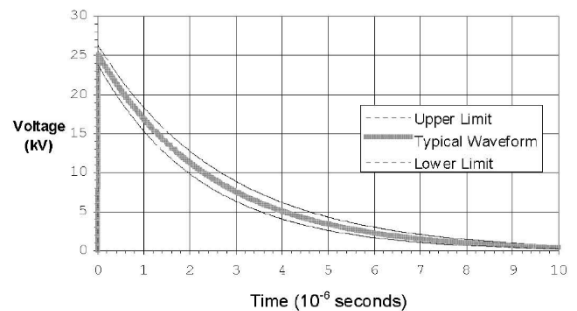

FIGURE F1-3. ESD Waveform (5000 ohm series resistance)

Fig. 11 5000Ω curve

Most important for these tests is the energy transferred to the detonator.

Section F1.4.2.1 Personnel-borne ESD test, describes this energy transfer in detail.

“The energy delivered to each of the calibration test loads given in Table F1-1 shall be between 0.18% and 0.22% (when using a 500 ohm series resistance) or between 0.018% and 0.022% (when using a 5000 ohm series resistance) of the energy stored on capacitor C”.

For the EMC PARTNER test system, the energy is calculated as follows:

$$E = \frac{1}{2} CV^2$$

Energy stored in C = 500 pF at 25kV = 0.156J =100%

Ratio 1Ω to 500Ω = 501 => 100%: 501 = 0.20% ± 10 % = 0.18 to 0.22%

Ratio 1Ω to 5000Ω = 5001 => 100%: 5001 = 0.020% ± 10 % = 0.018 to 0.022%

Tolerance at Tau (36.8% of Vmax) or any points of the curve is therefore +/- 10%

Tau = C x R = 500 x 10⁻¹² x 5000 = 2.5 x 10⁻⁶ => 2.25 μs up to 2.75 μs

Tau = C x R = 500 x 10⁻¹² x 500 = 0.25 x 10⁻⁶ => 0.225 μs up to 0.275 μs

Calibration definition for EMC PARTNER circuits is therefore:

ESD3000DN4 (5000Ω)

36.8% of the V_{peak} must be between 2.25μ and 2.75μs

ESD3000DN5 (500Ω)

36.8% of the V_{peak} must be between 0.225μ and 0.275μs

From this we can derive that the only clearly defined point on the curves is Tau.

Consequently EMC PARTNER measures only at the Tau point. Tau = 36.8% of 25kV = 9.2kV. This is illustrated in Figures 12 and 13.

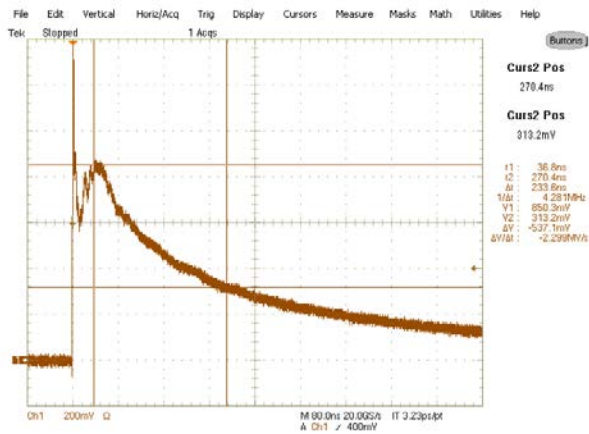

Fig. 12 DN5 (500Ω) Tau@ = 0.233us

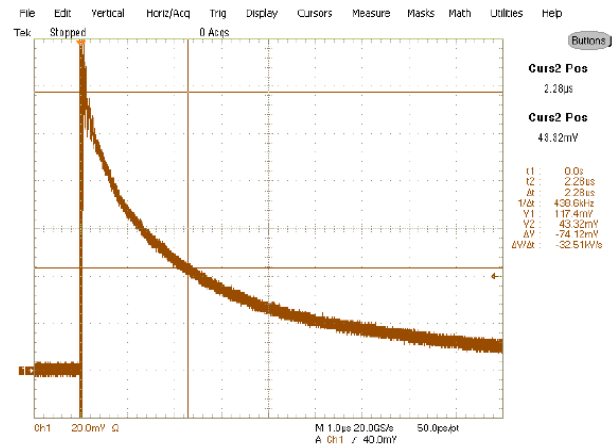

Fig. 13 DN4 (5000Ω) Tau = 2.3us

6 References

1. MIL-STD-331 Revision D, 2017
2. MIL-DTL-23659 Revision F, 2010
3. MIL-STD-461 Revision G, 2015
4. NATO AECTP-500 Revision 2, 2005