

White Paper

The new revision of MIL-STD-1275 and its requirement: injected voltage spikes

Author: Byungkyu (BK) Yoo
Product Manager - Defence

Created / Modified on: 26.11.2025

Supersedes document dated:

» Table of Contents

1	Abstract	3
2	Introduction	4
3	Assessment of the Standard Requirements	5
3.1	The Inconsistency: Circuit vs. Limit	5
3.2	The Interpretation and Solution	6
4	Proposed Solution	7
4.1	Adherence to the Standard: The Waveform	7
4.2	Circuit Implementation and Energy Verification: The 200 mJ and 0.5 Ω	7
4.2.1	<i>Typical Measurement Data</i>	8
4.2.2	<i>Verification Methodology</i>	8
4.2.3	<i>Energy Comparison Results</i>	9
4.3	Internal LISN for a Flexible Test Environment: A User-centred Application	10
5	Conclusion	13
6	References	14

1 Abstract

Advances in military vehicle technology have driven demand for testing under MIL-STD-1275F, which was introduced in 2022 with significant changes nearly a decade after the previous revision. By incorporating references to ISO 7637, this revision aligns military standards with commercial EMC practices, better reflecting real-world conditions. This white paper analyses the critical modifications to the 'Injected Voltage Spikes' test, specifically addressing the technical discrepancy arising from the tenfold reduction in maximum energy levels, from 2 J to 200 mJ. A notable inconsistency exists between the mandated test circuit, which theoretically produces 256 mJ, and the explicit 200 mJ energy limit defined in the standard. This requirement is therefore interpreted not as a theoretical circuit value, but as a verifiable performance benchmark for the generator output. Based on this methodology, the MIL3-1275F testing platform is introduced. This paper details how the system ensures unambiguous compliance and reproducibility through precise cosine-ring waveform generation and rigorous energy verification using a 0.5 Ω load. Furthermore, it highlights the integration of a flexible 5 μH LISN, offering a robust solution for modern defence compliance testing.

2 Introduction

MIL-STD-1275F mandates strictly defined power delivery at 28 V DC equipment terminals, reinforcing the established separation between generation and utilisation specifications seen in earlier revisions. While the standard's scope focuses heavily on transients, it fundamentally targets resilience against operational EMC hazards through rigorous spike and surge verification. A pivotal aspect of this modernised framework is the adoption of ISO 7637, which superseded SAE J1113-42, aligning immunity-testing criteria more closely with real-world conditions.

Within this context, the most critical update concerns the 'Injected Voltage Spikes' test. In particular, the maximum energy level has been reduced tenfold, from 2 J to 200 mJ, accompanied by rigorously standardised test circuits. This white paper analyses the technical implications of these changes, as summarised in Table 1, and introduces EMC PARTNER's platform, designed to ensure compliant verification.

Requirement	Revision A	Revision B	Revision C	Revision D	Revision E	Revision F
T_{rise}	< 50 ns	< 50 ns	< 50 ns	< 50 ns	< 50 ns	< 50 ns
V_{peak}	± 250 V	± 250 V	± 250 V	± 250 V	± 250 V	± 250 V
f_{osc}	100 kHz < f _{osc} < 500 kHz	100 kHz < f _{osc} < 500 kHz	100 kHz < f _{osc} < 500 kHz	100 kHz < f _{osc} < 500 kHz	100 kHz < f _{osc} < 500 kHz	20 kHz < f _{osc} < 500 kHz
Energy	Min. 15 mJ	Min. 15 mJ	Max. 15 mJ	Max. 15 mJ	Max. 2 J	Max. 200 mJ
Interval	50 spikes, 1 Hz	50 spikes, 1 Hz	50 spikes, 1 Hz	50 spikes, 1 Hz	50 spikes, 1 Hz	50 spikes, 1 Hz

Table 1. Changes to MIL-STD-1275 across versions

3 Assessment of the Standard Requirements

Interpreting a standard accurately creates the foundation for effective testing procedures. To resolve these complexities, one must balance three factors: the standard's intent, the engineering required, and the practicality of the test. EMC PARTNER analysed these facets to determine the correct methodology.

3.1 The Inconsistency: Circuit vs. Limit

A substantial discrepancy exists in the MIL-STD-1275F 'Injected Voltage Spikes' test. There is a clear conflict between the prescribed test circuit and the specified energy limit. The standard requires a standardised generation circuit that, by design, produces a theoretical energy spike of 256 mJ.

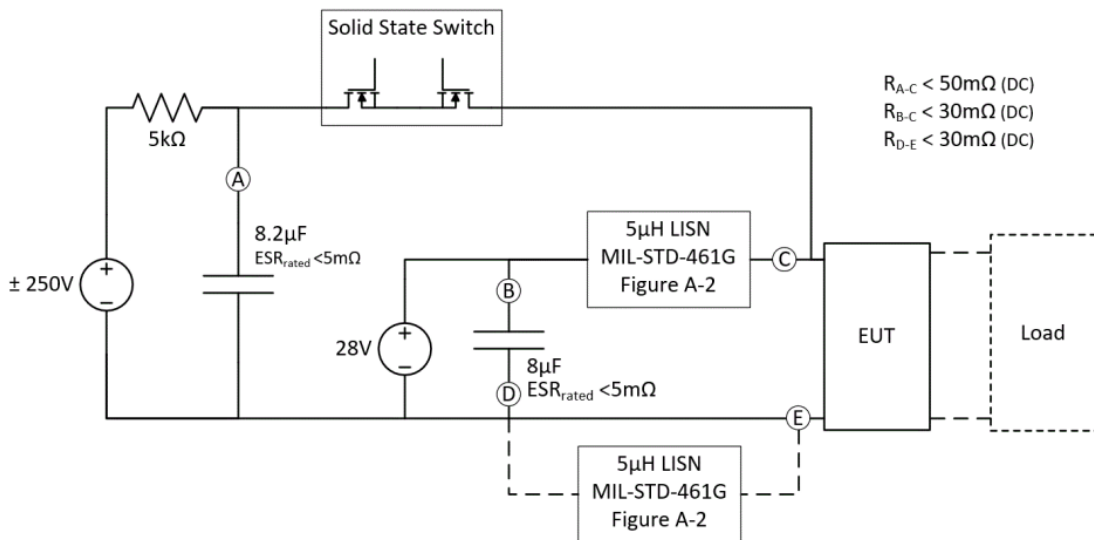

Figure 1. Sample test circuit for immunity to injected voltage spikes from MIL-STD-1275F

The theoretical energy produced by the circuitry in Figure 1 is derived using the following formula.

$$E = \frac{1}{2} \times C \times V^2$$

Where E is Energy in joules (J),
C is capacitance in farads (F),
and V is voltage in volts (V).

Given that $C = 8.2\mu F$ and $V = 250V$, the theoretical energy is:

$$\frac{1}{2} \times 8.2\mu F \times 250^2 \approx 256 \text{ mJ}$$

However, this value diverges from Clause 5.1.3.1.1 (Figure 2), which strictly limits the single spike energy content to 200 mJ. This creates a physical mismatch if interpreted literally.

5.1.3.1.1 Injected voltage spikes.

Utilization equipment shall operate without degradation or damage when subjected to voltage spikes within the envelope shown in Figure 7. The maximum rise time (t_{RISE}) of the injected spikes is 50 nanoseconds, and the maximum total energy content of a single spike is 200 millijoules (mJ).

Figure 2. Clause 5.1.3.1.1 from MIL-STD-1275F

3.2 The Interpretation and Solution

This inconsistency poses a challenge for test laboratories. However, rather than viewing these ambiguities as an error, EMC PARTNER interprets them as a critical distinction between theoretical potential and verified output.

It was determined that 256 mJ represents the energy produced by the defined circuit in a theoretical state. In contrast, the "200 mJ limit" serves as the verifiable performance benchmark for the generator's actual output. Therefore, the testing system must be calibrated to deliver no more than 200 mJ. While the energy ultimately absorbed by the Equipment Under Test (EUT) varies due to unique impedance characteristics, the generator itself must strictly adhere to the standardised 200 mJ limit.

Based on this insight, a solution was developed that satisfies both requirements: a system that utilises the required circuit design while ensuring a calibrated, compliant output of '200 mJ at 250 V'

4 Proposed Solution

To address the inconsistencies inherent in MIL-STD-1275F, particularly regarding the 'Injected Voltage Spikes' test, the MIL3-1275F testing system was developed. This innovative platform is designed to reconcile theoretical circuit potential with strict energy constraints, ensuring a compliant and reliable methodology. This section outlines the system's design principles and standards-based rationale, focusing on three key technical areas.

4.1 Adherence to the Standard: The Waveform

A valid transient test depends entirely on a precise, reproducible, and verifiable waveform. For the MIL-STD-1275F spike test, the system implements a cosine-ring wave. The reasoning follows directly from the standard, which implies this shape by specifying the line impedance.

Low Impedance Requirement: As illustrated in the standard's circuit diagrams (e.g., Figure 1), the pathway from the generator to the EUT is specified to have a very low impedance of approximately 50 m Ω .

Engineering Implication: The implication is unequivocal: any extraneous components that could modify the impedance between the energy-storage capacitor and the generator's output must be minimised.

Discharge Mechanism: Upon test commencement, the charged capacitor is rapidly discharged via a switch into this low-impedance pathway. This direct discharge, starting at the peak voltage, naturally produces an initial spike with a cosine waveform, followed by the oscillatory behaviour characteristic of a ring wave.

4.2 Circuit Implementation and Energy Verification: The 200 mJ and 0.5 Ω

The MIL3-1275F circuit was engineered with two primary objectives: ensuring spike stability and reproducibility. The principal technical challenge involved optimising the circuit's inherent inductance to generate a clean waveform without compromising the low-impedance path mandated by the standard.

The resulting system can produce a spike of up to 200 mJ at 250 V, with a resonant frequency fully compliant with the standard stipulations. This performance consistency is maintained across a broad voltage range; the specified resonant frequency and rise time are assured from 100 V to 400 V, while the system's effective testable voltage range extends from 20 V to 400 V.

4.2.1 Typical Measurement Data

The following tables present the typical measurement results for positive and negative spikes at 250 V, averaged over five impulses. All parameters, Peak Voltage (V_{peak}), Rise Time (T_{rise}), Oscillation Frequency (f_{osc}), and Waveshape Energy, fall well within the uncertainty limits. Notably, the average waveshape energy is approximately 197–198 mJ (see Table 2 and Table 3), demonstrating that the system is precisely calibrated to operate within the 200 mJ threshold.

+ 250 V	Value	Uncertainty	Pass / Fail
V_{peak} Avg.	250.16 V	$\pm 4 \%$	Pass
T_{rise} Avg.	12.301 ns	$\pm 5 \text{ ns}$	Pass
f_{osc} Avg.	25.406 kHz	$\pm 0.4 \%$	Pass
Waveshape Energy Avg.	197.750 mJ	$\pm 6.5 \%$	Pass

Table 2. Typical measurement of positive spikes of MIL3-1275F averaged over five impulses

- 250 V	Value	Uncertainty	Pass / Fail
V_{peak} Avg.	252.794 V	$\pm 4 \%$	Pass
T_{rise} Avg.	12.495 ns	$\pm 5 \text{ ns}$	Pass
f_{osc} Avg.	25.467 kHz	$\pm 0.4 \%$	Pass
Waveshape Energy Avg.	198.571 mJ	$\pm 6.5 \%$	Pass

Table 3. Typical measurement of negative spikes of MIL3-1275F averaged over five impulses

4.2.2 Verification Methodology

In military applications, pre-test verification is essential to validate compliance. While the performance data presented above demonstrate the generator's compliant output, calibration must be performed using a standardised, reproducible method.

Addressing Impedance Variability: During live testing, specifying the EUT's impedance is a primary source of test variability. A fundamental challenge is that a typical EUT constitutes a complex load rather than a simple one. Due to the unique impedance of each EUT, it is unrealistic to define a "standard load" for certification purposes based solely on the EUT.

Therefore, the logical and certifiable way to establish a reproducible benchmark is to adopt a methodology widely employed in EMC calibration: verifying performance with a standardised resistive load. This approach eliminates the unpredictable reactance of an EUT and provides a stable baseline for calibration.

The Rationale of 0.5 Ω: The engineering challenge lies in identifying the worst-case resistive load. Theoretical circuit analysis places this at approximately 0.5 Ω, where energy transfer is maximised. Following this detailed analysis, it was determined that the most effective method for verifying the 200 mJ energy output is to discharge the spike into a 0.5 Ω non-inductive load. This provides a stable reference point, ensuring strict compliance with the "not to exceed 200 mJ" specification prior to connecting the generator to the undefined impedance of a live test setup.

4.2.3 Energy Comparison Results

The verification results for the correct load are presented in Figure 3. The graph in Figure 3 plots the theoretical energy of the sample circuit (grey line) against the empirically measured energy from the calibrated MIL3-1275F (blue dots and orange stars) across the resistive load spectrum.

While the energy generated by the theoretical circuit evidently surpasses the 200 mJ threshold (denoted by the red line) at the identified worst-case point, the MIL3-1275F consistently operates below this limit throughout the entire range.

Conclusion: Consequently, this validation data does not constitute a simulation of a "real EUT." Instead, it serves as a vital benchmark, demonstrating that the MIL3-1275F is accurately calibrated to remain well within the 200 mJ limit, even under the most adverse resistive conditions. This provides users with a reliable, certifiable baseline for ongoing verification.

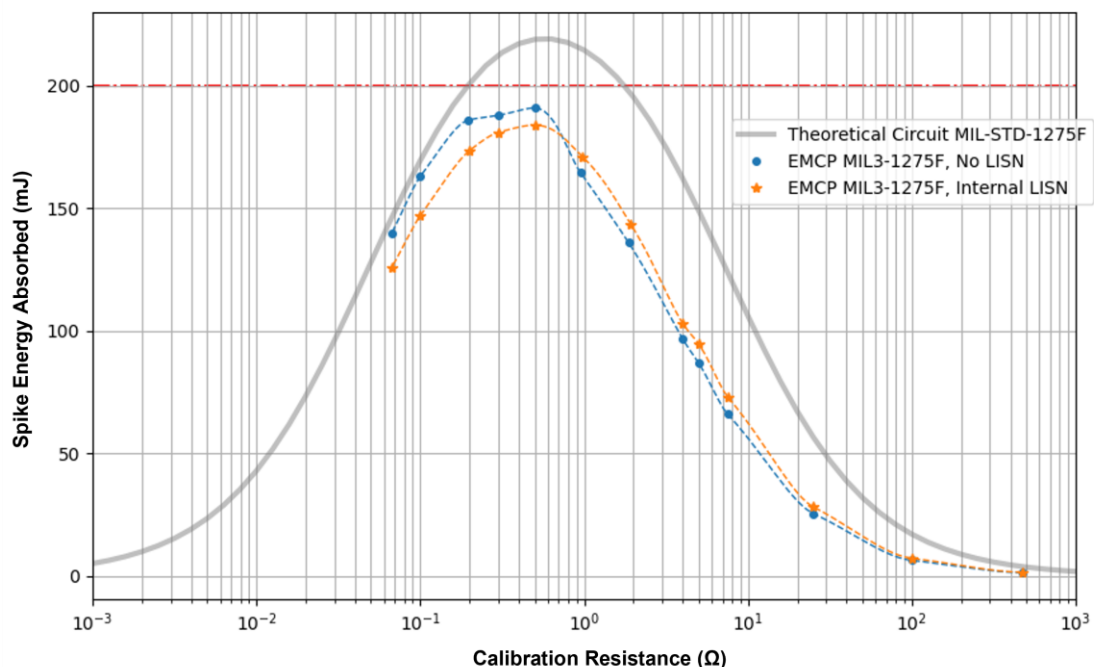

Figure 3. Energy comparison at 250 V between the theoretical circuit and the measured MIL3-1275F performances

4.3 Internal LISN for a Flexible Test Environment: A User-centred Application

The MIL3-1275F is engineered to address the evolving demands of the testing environment directly. For decades, the 50 μH LISN has served as the laboratory standard for bus impedance under MIL-STD-461. However, MIL-STD-1275F introduces a requirement for a 5 μH LISN, aligning with traditional automotive testing procedures. This specification mirrors the LISN defined in MIL-STD-461G for specific Conducted Emissions (CE) assessments, representing a significant modification for users accustomed to typical MIL-STD-461D through G configurations.

To facilitate a seamless transition and maximise operational flexibility, the system incorporates these unusual components directly. It features an internal, bypassable 5 μH LISN and the requisite 8 μF capacitor network. This design offers users two distinct operational scenarios:

Integrated Mode: The internal 5 μH LISN and 8 μF capacitor circuit. This enables immediate testing without modifying existing external configurations or acquiring additional hardware.

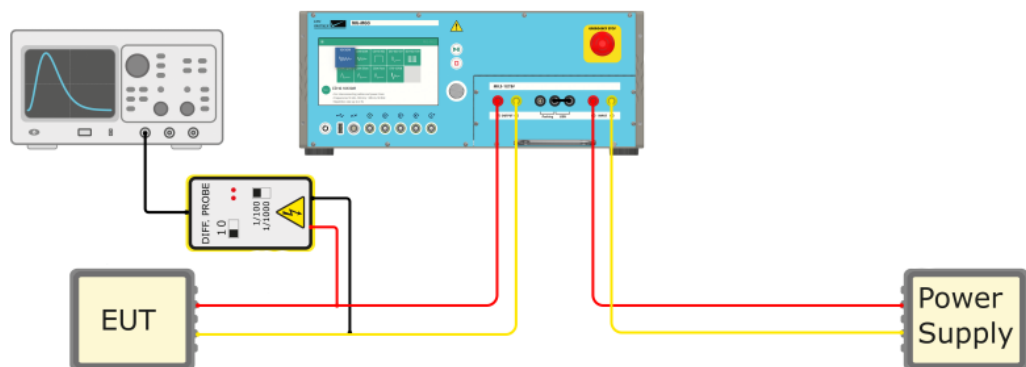

Figure 4. Sample Test Setup of MIL3-1275F with Internal LISN

Bypass Mode: For laboratories already equipped with a compliant external 5 μ H LISN, the internal circuitry can be bypassed. This allows the MIL3-1275F to be connected directly to the facility's configured power bus networks.

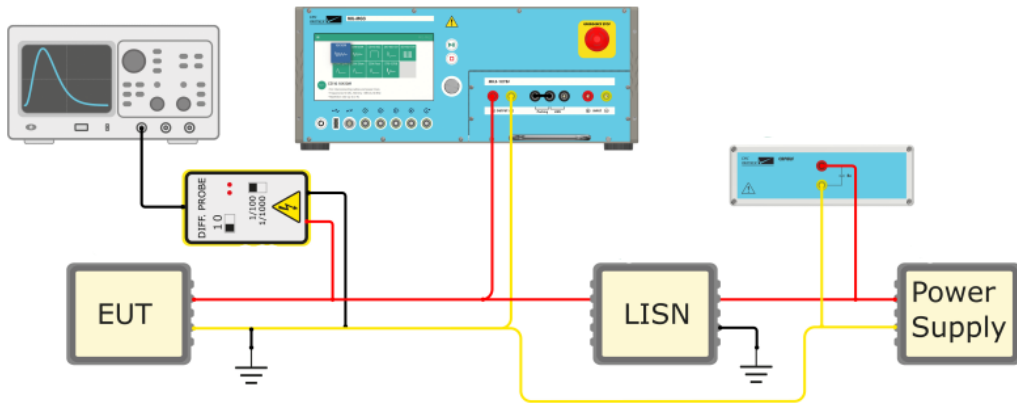

Figure 5. Sample Test Setup of MIL3-1275F with External LISN, grounded (Bypass Mode)

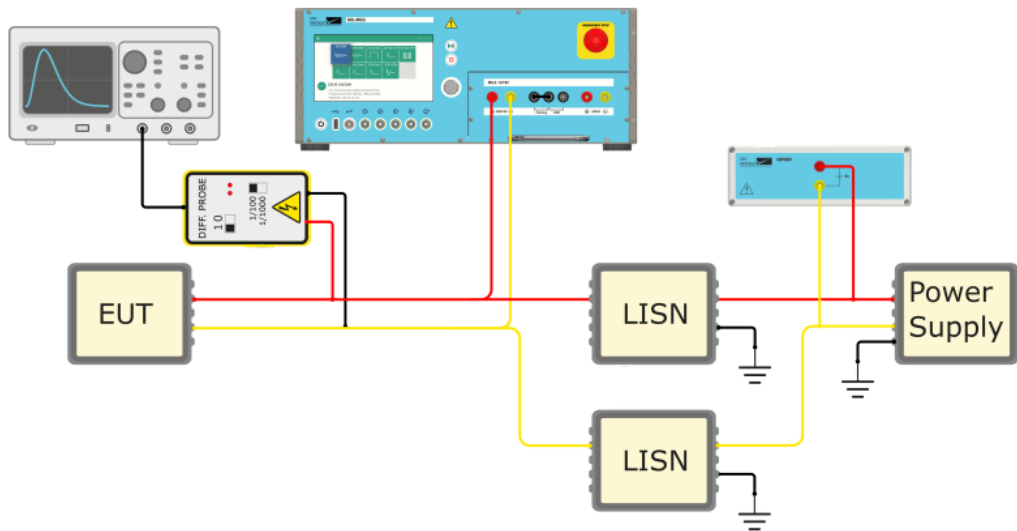

Figure 6. Sample Test Setup of MIL3-1275F with External LISN, ungrounded (Bypass Mode)

The dedicated capacitance: To fully support this mode, the standalone CAP8UF capacitor network is available and is explicitly designed for MIL-STD-1275F testing.



Figure 7. MIL3-1275F (P/N: 112101) and CAP8UF (P/N: 112169)

5 Conclusion

As military ground vehicles evolve into sophisticated electronic platforms, the need for comprehensive, unequivocal compliance testing becomes increasingly critical. While the implementation of MIL-STD-1275F represents a necessary modernisation, it has introduced uncertainty within laboratories due to the technical contradiction between the mandated circuit's theoretical potential (256 mJ) and the strict "not to exceed 200 mJ" limit.

To resolve this interpretive challenge, the MIL3-1275F was developed based on a fundamental insight: the standard's intent is for the 200 mJ limit to serve as a verifiable performance requirement for the generator itself. This solution is uniquely engineered to deliver the tangible value that matters most to the modern defence industry.

Unambiguous Compliance: The system is engineered to meet the standard's specific intent, delivering a calibrated, verifiable 200 mJ generator output. This eliminates interpretative ambiguity and ensures that test results are genuinely compliant.

Guaranteed Reproducibility: By generating a stable, consistent cosine-ringwave waveform, the system ensures that tests are dependable and repeatable, which is essential for validating the robustness of mission-critical electronic components.

Operational Flexibility and Seamless Integration: The inclusion of an integrated, bypassable 5 μ H LISN and 8 μ F capacitor offers exceptional versatility. Laboratories can utilise the system as a comprehensive, all-in-one solution without modifying existing setups, thereby streamlining the testing process and reducing operational costs.

In an era where mission success depends on electronic superiority, compromise is not an option. The MIL3-1275F from EMC PARTNER stands as the definitive solution, transforming the complex challenge of MIL-STD-1275F compliance into a precise, reliable, and efficient process. It provides the certainty that mission-critical systems are tested correctly, ensuring their resilience and readiness for modern defence applications.

6 References

MIL-STD-1275A: 1976
MIL-STD-1275B: 1997
MIL-STD-1275C: 2006
MIL-STD-1275D: 2006
MIL-STD-1275E: 2013
MIL-STD-1275F: 2022
MIL-STD-461D: 1993
MIL-STD-461E: 1999
MIL-STD-461F: 2007
MIL-STD-461G: 2015
SAE-J1113-42: 2006
SAE-J1113-42: 2010
ISO 7637-2: 2004
ISO 7637-2: 2011